



Telephone :

EN

# Indian Institute of Technology Madras

I.I.T. P.O., CHENNAI - 600 036.

Ref. No.

MEE 14-15 324 IITM KSR5 -III

Date : 30/6/16

Dear Sirs,

19/7/16  
DUE DATE : .....

1. Quotations are invited in duplicate for the various items shown below / overleaf / enclosed list.
2. The Quotations duly sealed and superscribed on the envelope with the reference No. and due date, should be addressed to the undersigned so as to reach him on or before the due date stipulated above.
3. The Quotations should be valid for sixty days from the due date and the period of delivery required should also be clearly indicated.
4. If the item is under DGS & D Rate contract. Rate Contract Number and the price must be mentioned. It may also please be indicated whether the supply can be made direct to us at the Rate contract price. If so, please send copy of the R.C. (Please note that we are not Direct Demanding Officers)
5. Relevant literature pertaining to the items quoted with full specifications (and drawing, if any) should be sent along with the Quotations, wherever applicable samples if called for, should be submitted free of charges, and collected back at the supplier's expenses.
6. Local Firms : Quotations should be for free delivery to this Institute. If Quotations are for Ex-Godown, delivery charges should be indicated separately.
7. Firms Outside Chennai : Quotations should be for F.O.R. Chennai. If F.O.R. consignor station, freight charges by passenger train / lorry transport must be indicated. If-Ex-Godown, packing, forwarding and freight charges must be indicated.
8. The rate of Sales / General Taxes and the percentage of such other taxes legally leviable and intended to be claimed should be distinctly shown along with the price quoted. Where this is not done, no claim for Sales / General Taxes will be admitted at any stage and on any ground whatsoever. The taxes leviable should take into consideration that we are entitled to have Concessional Sales Tax applicable to Non-Government Educational Institutions run with no profit motive for which a concession. Sales Tax Certificates will be issued at the time of final settlement of the bill.
9. Goods should be supplied carriage paid and insured.
10. Goods shall not be supplied without an official supply order.
11. Payment : Every attempt will be made to make payment within 30 days from the date of receipt of bill / acceptance of goods, whichever is later.

Details as per enclosed list.

Yours faithfully

**Dr. K. SRINIVAS REDDY**  
Professor  
HEAD OF THE DEPT. /  
PROJECT CO-ORDINATOR  
Heat Transfer and Thermal Power Laboratory  
Department of Mechanical Engineering  
Indian Institute of Technology Madras  
CHENNAI-600 036.



\*Strike out whichever is not applicable.

**BILL OF MATERIAL**

S.NO	Item	Quantity
1	MS L – Channel (75 x 75 x 5 mm)	2 Length
2	Square Sintex Tank (300 litres)	2
3	MS sheet (2400 x 1200 x 5 mm)	3
4	MS sheet (2400 x 1200 x 1.2 mm)	3
5	Western Toilet	2
6	PVC side covers (1135 x 985 x 3 mm)	18
7	MS hollow square tube (80 x 80 x 5 mm)	26
8	MS sheet (2400 x 1200 x 5 mm)	3
9	MS sheet for staircase (2500 x 1350 x 5 mm)	2
10	Cast iron wheels with stopper (6 inch)	10
11	PVC Door with hinges and lock	2
12	Necessary fittings and accessories (Bolts, nuts, screws, painting)	Required numbers

*[Handwritten Signature]*



**Dr. K. SRINIVAS REDDY**  
Professor  
Heat Transfer and Thermal Power Laboratory  
Department of Mechanical Engineering  
Indian Institute of Technology Madras  
CHENNAI-600 036.

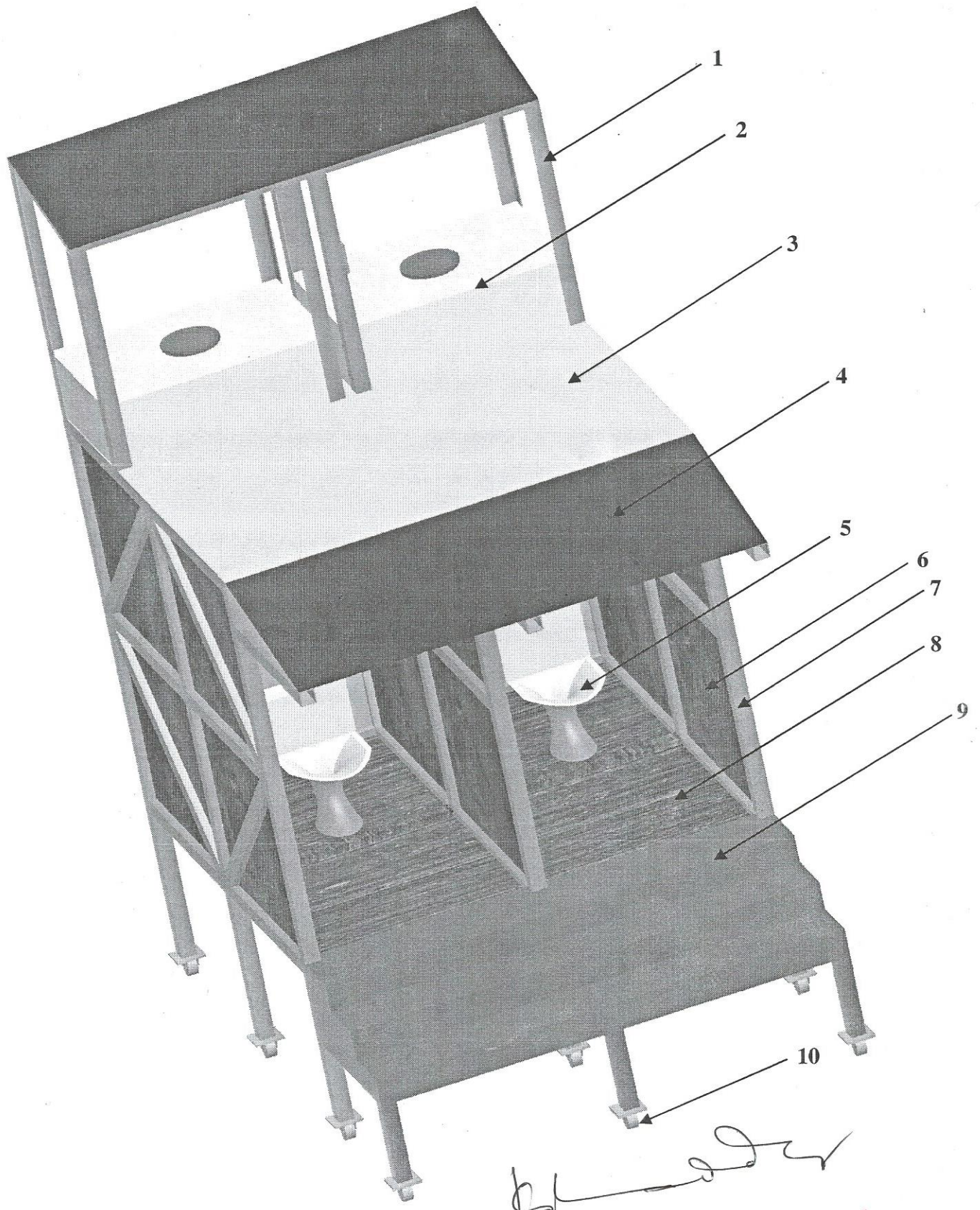

*[Handwritten signature]*

**Dr. K. SRINIVAS REDDY**  
Professor  
Heat Transfer and Thermal Power Laboratory  
Department of Mechanical Engineering  
Indian Institute of Technology Madras  
CHENNAI-600 036.



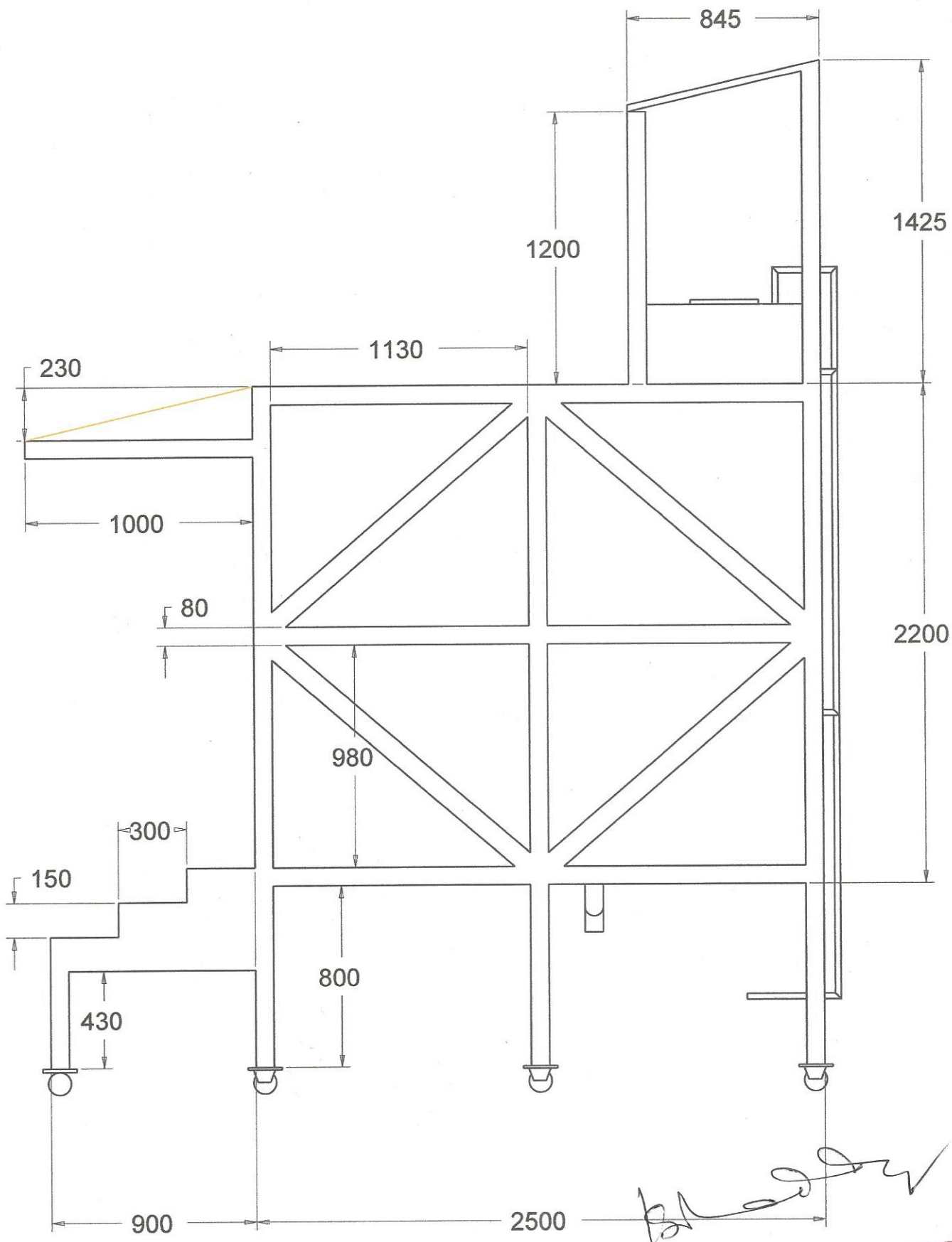

*Handwritten signature*

All Dimensions are in mm



**Dr. K. SRINIVAS REDDY**  
 Professor  
 Heat Transfer and Thermal Power Laboratory  
 Department of Mechanical Engineering  
 Indian Institute of Technology Madras  
 CHENNAI-600 036.

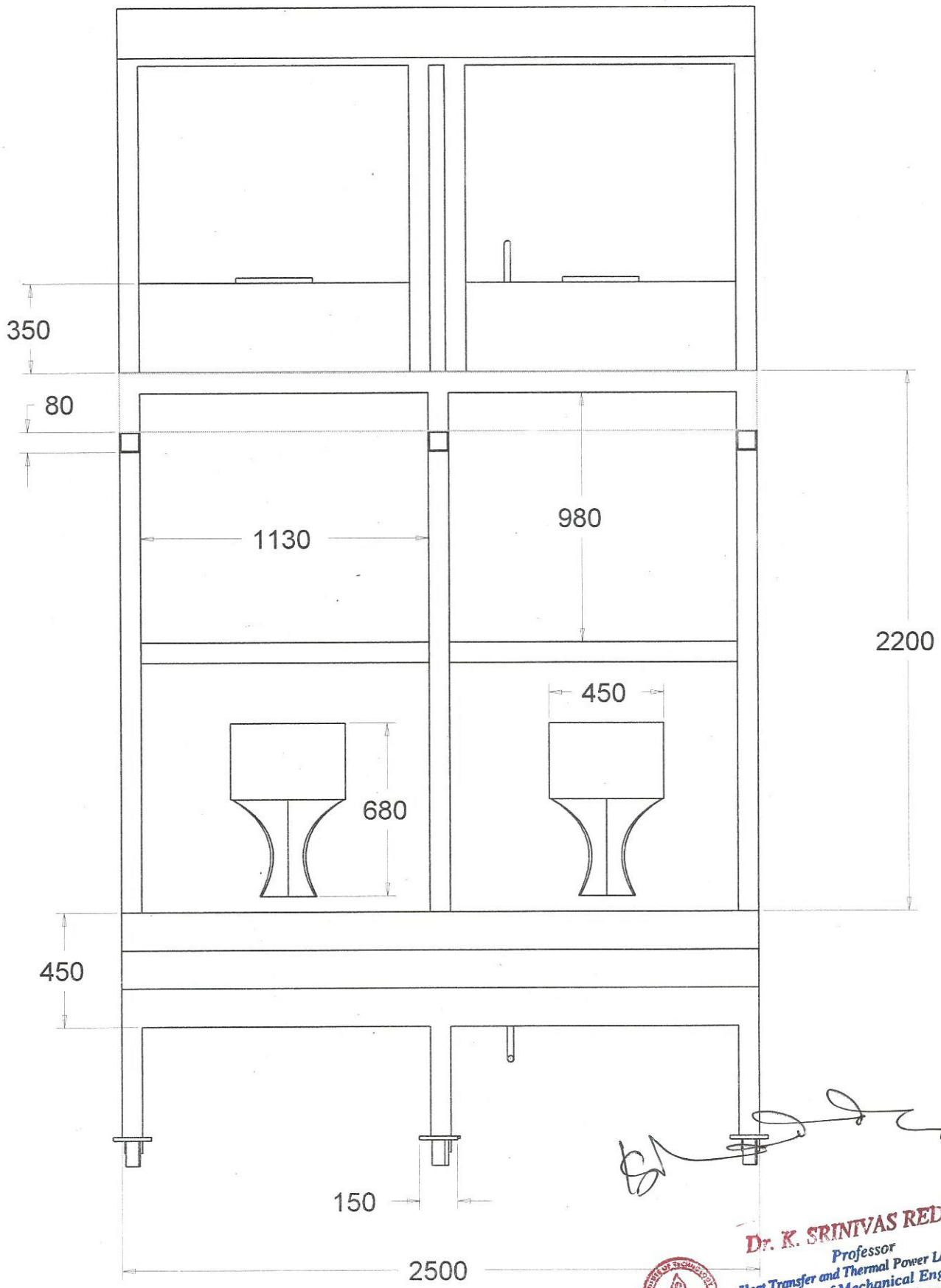

All dimensions are in mm



**Dr. K. SRINIVAS REDDY**  
 Professor  
 Heat Transfer and Thermal Power Laboratory  
 Department of Mechanical Engineering  
 Indian Institute of Technology Madras  
 CHENNAI-600 036.