

Technical specifications
Supply of 2 Nos. of Industrial Robots

For the project on

**Automated Robotic Air Coupled Ultrasonic Inspection for
Composite Structure**

1.0. Scope of work

Supply and commissioning of two numbers of cooperating industrial robots along with accessories to be used for the inspection of composites using air coupled ultrasonic technology.

2.0. Statement of purpose

The heart of the automated inspection system for composite structures is an inspection cell comprising two cooperating 6-axis robot arms, capable of working independently and cooperatively. The robotic arms will carry end-effectors having ultrasonic transducers. The movement of the robots has to be synchronized with the ultrasound signal acquisition through a software developed by the purchaser. The robots can be taught by teach pendent or via off-line programming method. The purchaser intends to develop the software with the following features

- The operator can load the inspected component geometry CAD file into a software application, and pick the areas to be inspected.
- The operator can teach the component geometry of the areas to be inspected.
- The software then generates the scan path for the robot.
- The robot motion can be simulated in a 3D environment to verify non-collision and robot reach limits prior to actual deployment.
- Data acquisition and synchronization

3.0. Technical specifications

3.1. Robot arm features

Number of axes	6 axes simultaneous motion
Payload (minimum)	20 kg at the end effector
Repeatability (better than)	0.1 mm
Accuracy (better than)	0.1 mm
Reach	1.65 m to 2.0 m
Mounting method	Floor mounted
Type of drive system	Electric
Motors	Servo motors with absolute encoders and holding brakes
Degrees of freedom	6 rotating joints
Ambient temperature	45 degree C maximum
Dressing option	To carry cables of maximum diameter 50 mm from the end effector to the robot base
Protection	IP 67

3.2. Robot control system features

Digital I/O board support	Option for extending if required in future
Digital inputs (minimum)	16
Digital outputs (minimum)	16
Cable length (robot to control box) (minimum)	10 meters
Cable length (robot to HMI) (minimum)	5 meters
Input power supply	230V / 440 V AC, 50 Hz
Ambient temperature	45 degree c maximum
Electrical noise compliance	Low EMC as per IEC 61800-3 Category 2 or better
Teach pendant	The teach pendant should be compact, lightweight and should have color LED display
Emergency stop feature	Emergency stops on control cabinet and teach pendant
Computer control	Controller shall have the Ethernet communication features for interfacing with computer
Programming	Teach pendant and offline programming capabilities
Offline programming tool license	Minimum 50 user license with perpetual validity
Support for external axes	2 axes including the motor and drive unit. Each robot should have one external axis each under its control. Support for 3 more axes on each for future expansion
External axis	Motor and drive unit to be supplied
Licenses and software add ons	All licenses and software add ons required for attaining the intended functionality of the system needs to be supplied

3.3. Robot motion features

Independent movements	Both the robots should be independently operated.
Concurrent cooperation	A simultaneous motion start time is forced for both the robots at synchronization point t_0 . No position or orientation constraints exist in this type of cooperation.
Coupled synchronous cooperation	A simultaneous motion start time is forced for both the robots at synchronization point t_0 . Both the robots are synchronized and perform identical line or circle arc motions and no relative motion exists between master and slave end-effectors. The slave robot follows

	the motions of the master robot, without executing motion blocks of its own
Combined synchronous cooperation	An identical motion time is forced for both the robots in the synchronization period Dt . The master robot performs a basic line or circle arc motion, while the slave perform different motion blocks relative to the end-effector frame of the master, producing a superposed motion on the basic motion of the master robot.

4.0. Features required

4.1. Geometric coupling

The two cooperating industrial robots should have the ability to exchange geometric information (position and its derivatives) from one robot to another which helps the robot to know where the other robot is in the work cell. The geometric coupling between robots can be activated in the movement routine in two modes: direct mode or indirect mode.

4.1.1 Direct coupling mode

In the direct geometric coupling mode, the slave will move as the master moves in a relation defined by the user. The functionality couples a robot (slave) with the base system of other robot (master). When the master is jogged, the slave follows its motions. The reference position between the robots for performing the tasks can be defined by the user.

4.1.2 Indirect coupling mode

The slave follows the motions of the master robot indirectly. The slave robot performs superposed, synchronous linear or circular motions.

4.2. Software development kit

Computer software modules (SDK) must be available to access robot controller from PC. All the necessary software modules required to develop software in C# (.NET 4.5) must be provided as part of the SDK. PC and robot controller should be communicating through Ethernet. Required features of SDK will include

1. **Access to file system of robot controller** - Using the SDK it should be possible to create, save, load, rename, and delete files in the robot controller file system. It should also enable the PC to create and delete directories. Feature to load files from PC to controller and vice versa must be available in SDK
2. **Access to IO system** - It should be possible to read all digital and analog IN and set any of digital or analog OUT of robot controller using SDK
3. **Access to Program variables** - SDK should have the feature to read and modify the variables defined in the program of robot controller.

4. **Read live position of TCP** - It should be possible to read live position of TCP (X, Y and Z position along with its orientation). SDK should have built- in library functions to do calculations with TCP position such as translate by a distance in X, Y or Z axis, position w.r.t world coordinate system, tool coordinate system etc. It also should be possible to read position of axes position of individual joints (A1, A2 A3, A4, A5 and A6)
5. **Access to Event Log** - The event log of controller status, program execution status or other log generated in robot controller must be accessible using SDK.

4.2.1 Offline Simulation and Programming Software

A PC software package to create and run robot controller program to be provided. Main features are

1. **Simulated Virtual Robot** - The software should have the feature to create and program virtual robot in its simulated environment. The software should provide library of all robots models and its variant available with that manufacturer. Virtual robot must a complete DIGITAL TWIN of actual robot. Virtual robot should support adding digital IO, analog IO, external axes etc. in simulated mode. The virtual robot controller must be accessible using the SDK provided by the manufacturer.
2. **Virtual Teach Pendant / HMI** - PC Software should have virtual teach pendant which must be exact simulated model of actual Teach Pendant. It must be possible to control the virtual robot in simulation environment including jogging, edit the program using the virtual teach pendant.
3. **Configuration, File and Program editor** - PC Software must have provision to manage all configuration of the robot. This will include managing file system, IO system, communication settings etc. There should be a comprehensive program editor with syntax highlight and auto code completion option. The PC software must support compiling and error checking of the program generated in the program editor.
4. **3D graphical UI for Task simulation** - The proposed software should have a 3D graphical window where the virtual robot(s) will be placed and manipulated to generate desired moves. It should support importing multiple CAD objects and other robots to simulate the complete robot task in offline mode. Software should have the tools to move the robot to desired position by free jogging or joint move using mouse pointer. It should also have the option of selecting a feature of imported model (edges, face etc) and create a robot path w.r.t the feature. Simulation should include, 3D visualization of robot and other object movements, collision detection, cycle time estimation etc. The estimated path and cycle time in simulation mode should match to actual very closely (more than 99% match).

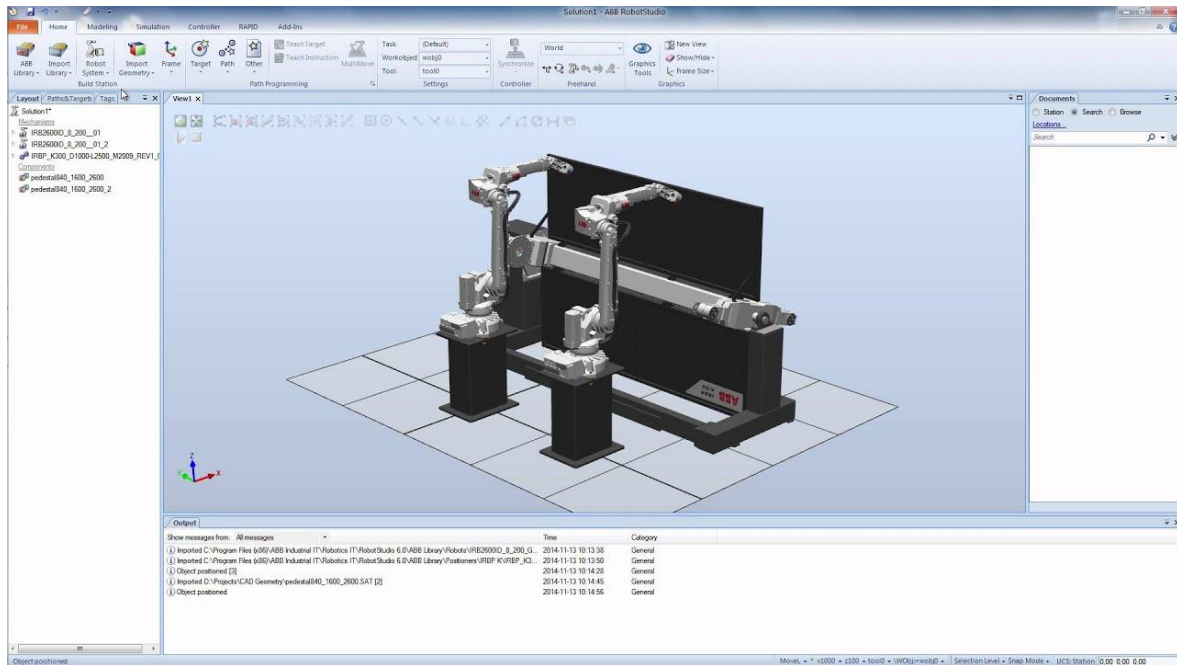

Fig 1 A typical 3D graphical window for robot task planning and simulation.

5. **Working in Offline and Online mode** - The software should support uploading the designed and simulated task created in PC directly to the robot controller(s). It should also be possible to import entire robot data to PC simulation environment and do the editing, teaching and programming from PC software.

4.3. External axes motor and drive

A standardized motor unit package complete with cabling, drive, accessories and safety options should be supplied. These standard motor units have to be controlled by the robot and the pendent supplied. There should be an option to include this motor as an external axis in the robot control system. The motors should be equipped with brakes for positional control. The motors supplied needs to have a minimum dynamic torque of 14 Nm. The robot controller should have at least 3 free slots for adding additional motor and drive for future use.

4.4 Force/Torque control (to be quoted optional)

A force/torque sensor can be employed with the essential accessories to communicate with the robot control system for one robot so that the force and torque at the robot TCP can be measured. A lead through programming method can also be approached for the easy teach and learn functionality of the system.

5.0. Eligibility to quote

1. Only vendors who are also manufacturers of articulated robots are eligible to quote.
2. The vendor should be a manufacturer as mentioned in item (1) and not a consortium or a dealer.
3. The manufacturer should have more than 10 years of experience in the field of manufacturing the articulated robot.

4. The vendor should have supplied at least 5 robots within last 12 months (of the same type as offered to IITM) in India. List supplied with contact information must be provided for verification.
5. The vendor must have a full-fledged service and training facility that is located in India

6.0. Scope of supply

Sl No	Item	Quantity
1	Cooperative industrial Robot with the control system, cables and software	2 Nos
2	Motor for external axis along with associated drive and cables	2 Nos
3	Offline programming software	1 No
4	Software for Ethernet communication and cooperative operation for 2 robots	1 No
5	Training for 6 people for 5 days on cooperative operation and basics	included
6	Transport, installation and commissioning	included

7.0. Acceptance criteria

1. The vendor should demonstrate the operation of the cooperative robots in concurrent cooperation, coupled synchronous cooperation and combined synchronous cooperation as defined in section 3.0.
2. The vendor should demonstrate the use of the offline programming tool to develop a trajectory. He should download it to the robot supplied from the offline programming tool and demonstrate it on the robot.
3. The vendor should demonstrate the features of PC SDK and give a sample program.

The acceptance of the robots will be strictly on successful demonstration of the aforesaid demos along with compliance

8.0. General Instructions

1. Quotation should contain item wise price for each item of our enquiry. (Detailed cost breakup of each item viz. Equipment cost, conversion cost, testing cost, any other charges wherever applicable).
2. The quotations should be valid for a minimum of 90 days from the due date.
3. Other applicable levies if any to be specified separately like, insurance, transportation, packaging & forwarding etc. for the total supply.
4. The party should have a well-equipped authorized service and support center in India.
5. The party should have a full-fledged training facility within India.
6. Suppliers shall enclose the complete product sheet of the equipment along with its compliance/calibration certificate.
7. Offer received shall confirm the compliance to our technical requirement
8. All the suppliers should prove the technical compliance features before the purchaser.

9. All the delivered equipment's should be accompanied with their respective compliance/calibration certificates. Equipment's supplied without valid compliance/calibration certificates are liable to be rejected.
10. The supplier shall indicate time required for procurement, delivery period and other duration like time required for installation very clearly.
11. Detailed breakup of overall cost should be clearly specified. Overall cost will be compared and should include packaging, forwarding and safe delivery to IITM.
12. IIT Madras is exempted from payment of import IGST and is eligible for concessional rate of customs duty. Necessary certificates will be issued accordingly at the time of clearance
13. All manuals in English language shall be supplied. All the necessary instruction, detailed wiring and circuit diagrams shall be supplied.