



INDIAN INSTITUTE OF TECHNOLOGY MADRAS

OFFICE OF THE DEAN (STUDENTS)

Chennai 600 036

Phone: [044] 2257 8051 Fax: [044] 2257 8052 Email: dostoffice@iitm.ac.in

Dated: 13th June, 2014

Due Date: 27th June, 2014/ 4.00PM

1. Quotations are invited in duplicate for the item shown in the enclosed list.
2. The Quotations duly sealed and super scribed on the envelope with the reference No.F/Purchase/07/2014 and due date, 27th June, 2014 should be addressed to **The Dean (Students), IIT Madras, Chennai – 600 036**, so as to reach the office of the Dean (Students) on or before the due date stipulated above.
3. Sample item should be shown to the Purchase Committee, Office of the Dean (Students), dated 30th June 2014 for verification of technical evaluation.
4. The quotation should be valid for sixty days from the due date, and the time required for delivery after date of Purchase order should also be clearly mentioned.
5. Quotations should be for free delivery to this Institute.
6. The rate of Sales/ General Taxes and the percentage of such other taxes legally livable and intended to be claimed should be distinctly shown along with the price quoted.
7. Goods should be supplied carriage paid and insured.
8. Goods shall not be supplied without an official supply order.
9. Payment: Every attempt will be made to make payment within 30 days from the date of receipt of bill /acceptance of goods, whichever is later.
10. The Supplier should Quote TIN/VAT/Service Tax and PAN Number along with the Quotation. Incomplete Quotations will not be considered.
11. The material should be supplied within 25 days on receipt of purchase order.

Yours Sincerely,

Dean (Students)



INDIAN INSTITUTE OF TECHNOLOGY MADRAS

OFFICE OF THE DEAN (STUDENTS)

Chennai 600 036

Phone: [044] 2257 8051 Fax: [044] 2257 8052 Email: dostoffice@iitm.ac.in

Sl. No.	Description	Qty (Nos)	Rate per item	Amount
1.	Steel Single Cot Deluxe Size 72" Length, 30" Berth, 24" Leg Head side and 18" Leg Other side with 18G sheet and 20G ER W tubular legs	700		

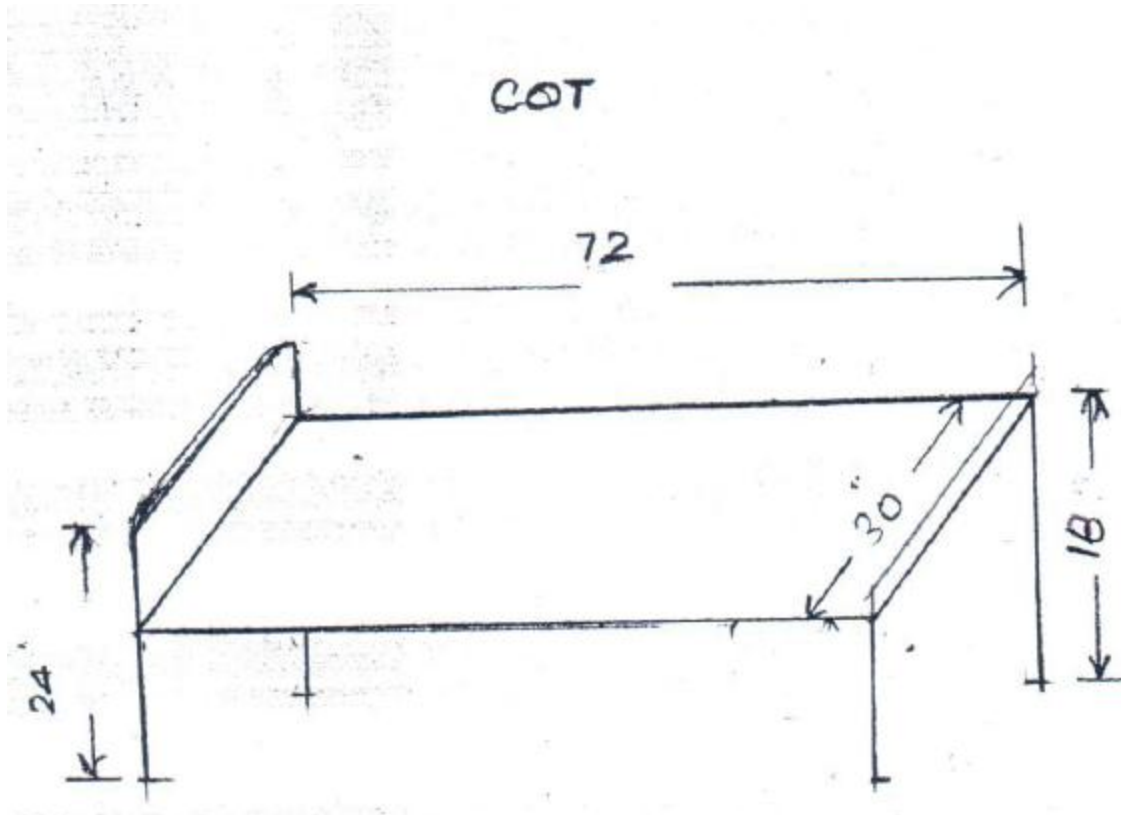

Yours Sincerely,

Dean (Students)